

ASSEMBLY INSTRUCTION
LA SALLE DRESSER WITH MIRROR
ITEM CODE 64529

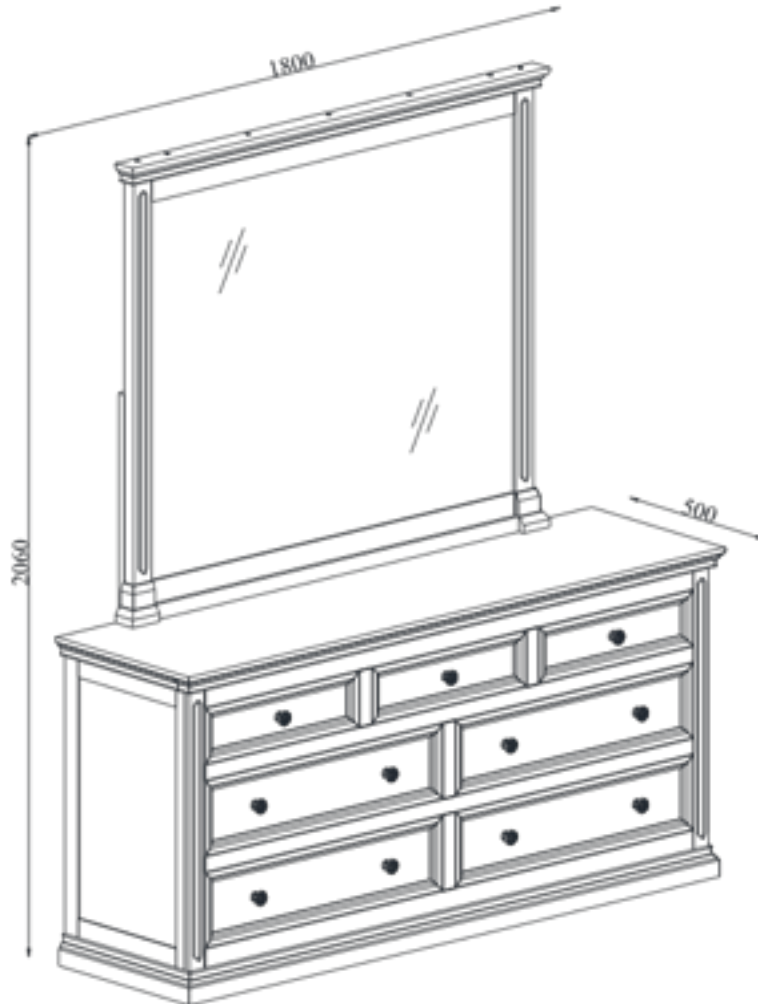

CAUTION: HEAVY ITEM

Imported by Amart Furniture Pty Ltd, Qld, Brisbane Australia.
For any assistance with assembly or for missing parts please phone
Amart Furniture, Customer Service Free call 1800 351 084



IMPORTANT: CARE GUIDE FOR YOUR TIMBER FURNITURE

- *Congratulations! You have just purchased a quality product from Amart **Furniture**. Please read on for important information regarding your purchase.*
- A multi-step finish is applied to all our furniture, but all wood comes from nature. Because of this, there will be natural variations in surface texture and grain like knots, mineral streaks and sap runs that may affect the finish.
- These differences in character are not defects, but distinctions that make each piece of furniture unique.
- Our furniture is built to last. Following these steps for basic care should protect your investment for years to come.
- Dust frequently with a clean damp lint-free cloth. This will help remove abrasive build up which can damage a finish over time.
- Do not place hot objects on any furniture surface. Always use a **coaster** or placemat. Laminate and lacquer finishes on table tops provide added scratch and heat resistance to our furniture, but they can still be damaged without proper care.
- Avoid exposing your furniture to strong sunlight, heat **outlets**, open windows or dampness. Prolonged exposure to direct sunlight can fade the finish of your furniture, while extreme temperature and humidity changes can cause cracking or splitting.
- Do not expose your furniture to any liquids. Never allow water to sit on your furniture. Alcohol, nail polish and perfume are also dangerous as they will dissolve the lacquer finish on contact and may require professional repairs.
- Do not allow plastic to come in direct contact with your furniture. Chemicals in the plastic of placemats etc may soften and mark the finish if left in contact with the furniture for a period of time.

PRE-ASSEMBLY PREPARATION

Before you start:



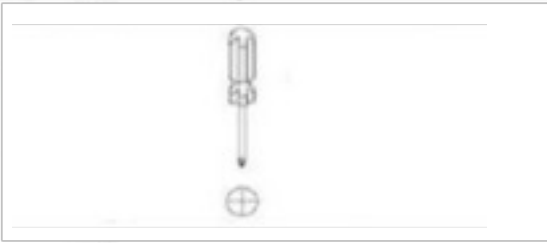

1. Choose a clean, level, spacious assembly area. Avoid hard surfaces that may damage the product
2. Take care when lifting. Product should be assembled as near as possible to the point of use
3. Ensure that you have all required contents for complete assembly
4. Always read the assembly instructions carefully before beginning assembly.
5. Keep all hardware parts and packaging out of reach of small children.
6. Do not over tighten the screws and bolts as this may damage the threads

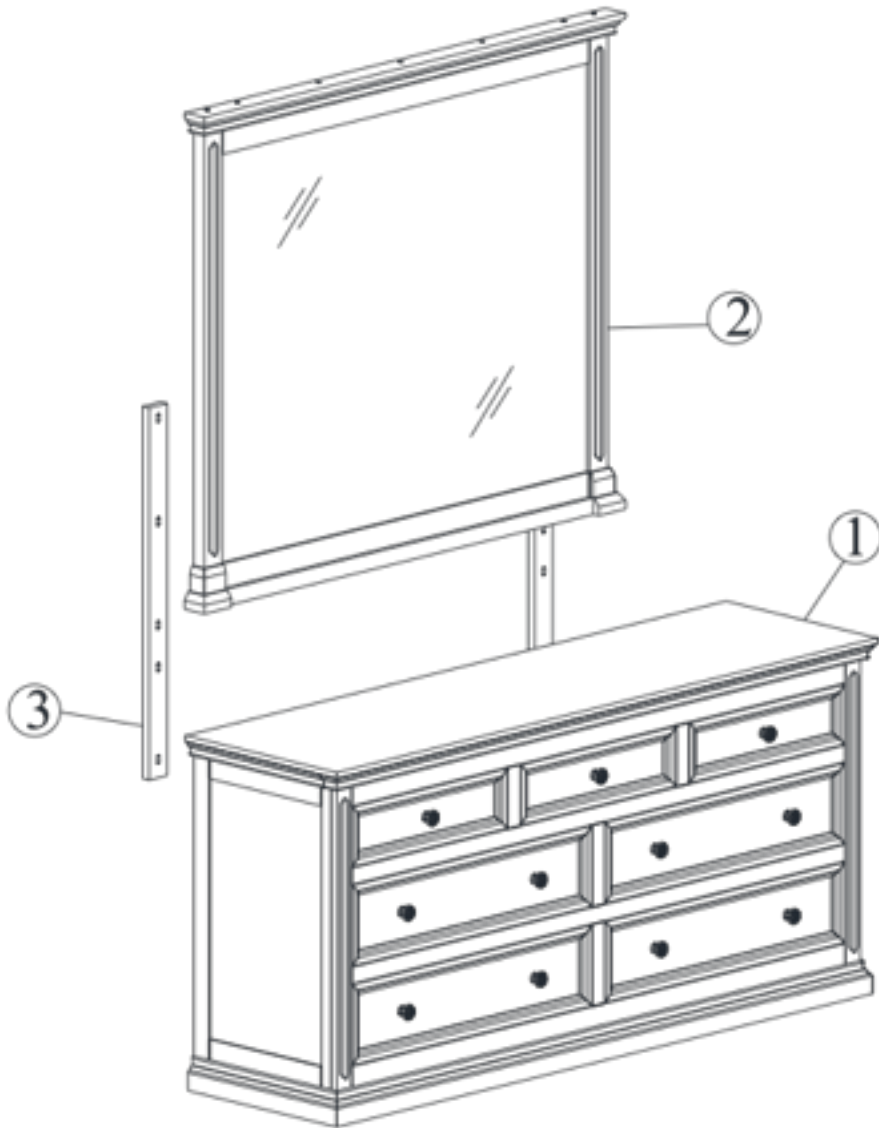
	
Allow at least 15min	you will need 2 people
	
ADDITIONAL TOOLS REQUIRED	

PARTS LIST



Part	DESCRIPTION	Qty	In box
1	DRESSER	1	1
2	MIRROR	1	2
3	SUPPORT BAR	2	2



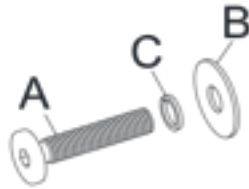

<p>A M6 X 45 BOLT 10 PCES</p> 	<p>B M6.5 X 19 FLAT WASHER 10 PCES</p> 	<p>C M6.5 X 9 SPRING WASHER 10 PCES</p> 	<p>D ALLEN KEY 1 PCE</p> 
---	--	---	--

Step 1

You will need to assemble the M6 x 45 bolts (item A) with the M6.5 x 9 spring washers (item C) and the M6.5 x 19 flat washers (item B)



YOU WILL NEED

A M6 X 45 BOLT 4 PCES 	B M6.5 X 19 FLAT WASHER 4 PCES 	C M6.5 X 9 SPRING WASHER 4 PCES 	D ALLFN KFY 1 PCE 
---	--	---	---

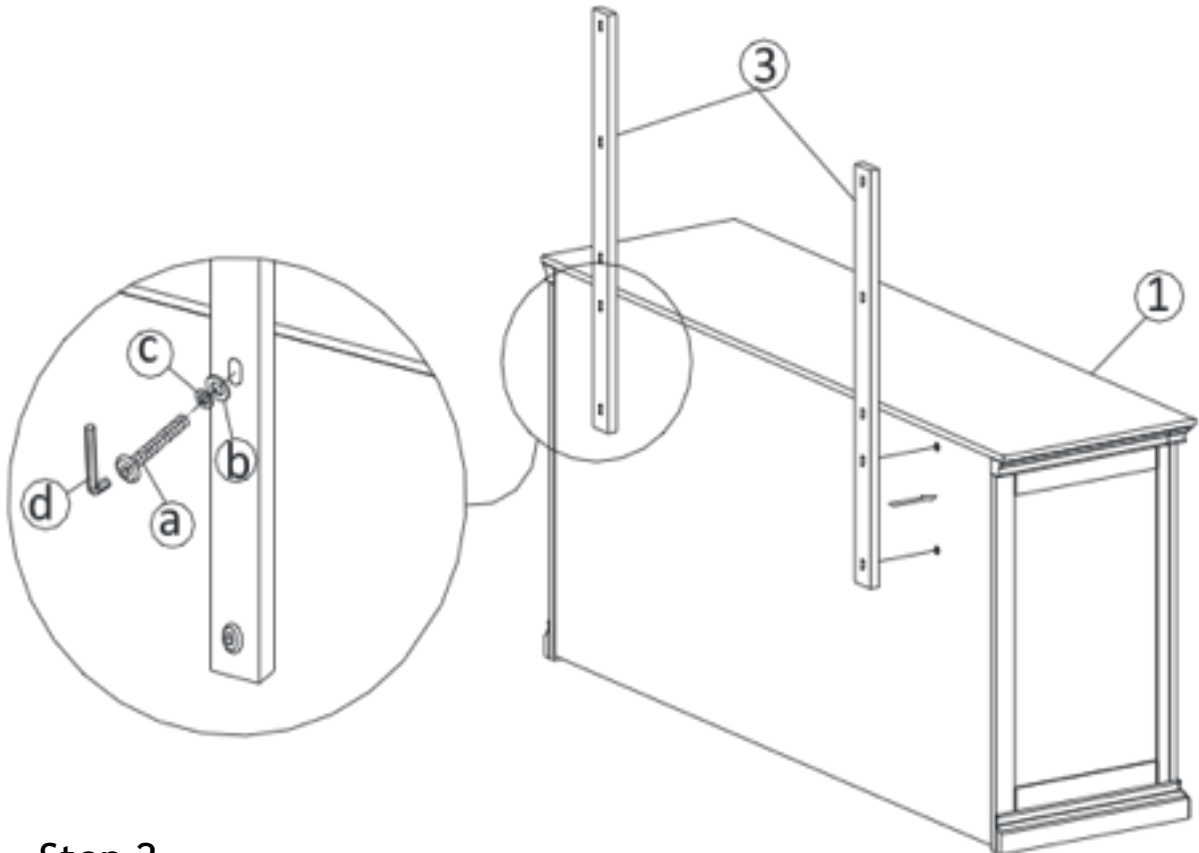

Step 2

Attach a support bar (Part 3) to the Dresser as shown using 2 of the assembled sets from Step 1, using allen key (item D).





Step 3

Repeat for other support bar.

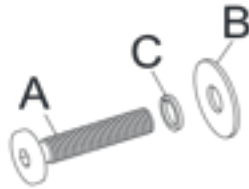
Step 4

Next you will need to assemble the M6 x 45 bolts (item A) with the M6.5 x 9 spring washers (item C) and the M6.5 x 19 flat washers (item B).



A M6 X 45 BOLT 6 PCES 	B M6.5 X 19 FLAT WASHER 6 PCES 	C M6.5 X 9 SPRING WASHER 6 PCES 	D ALLFN KFY 1 PCE 
---	--	---	---

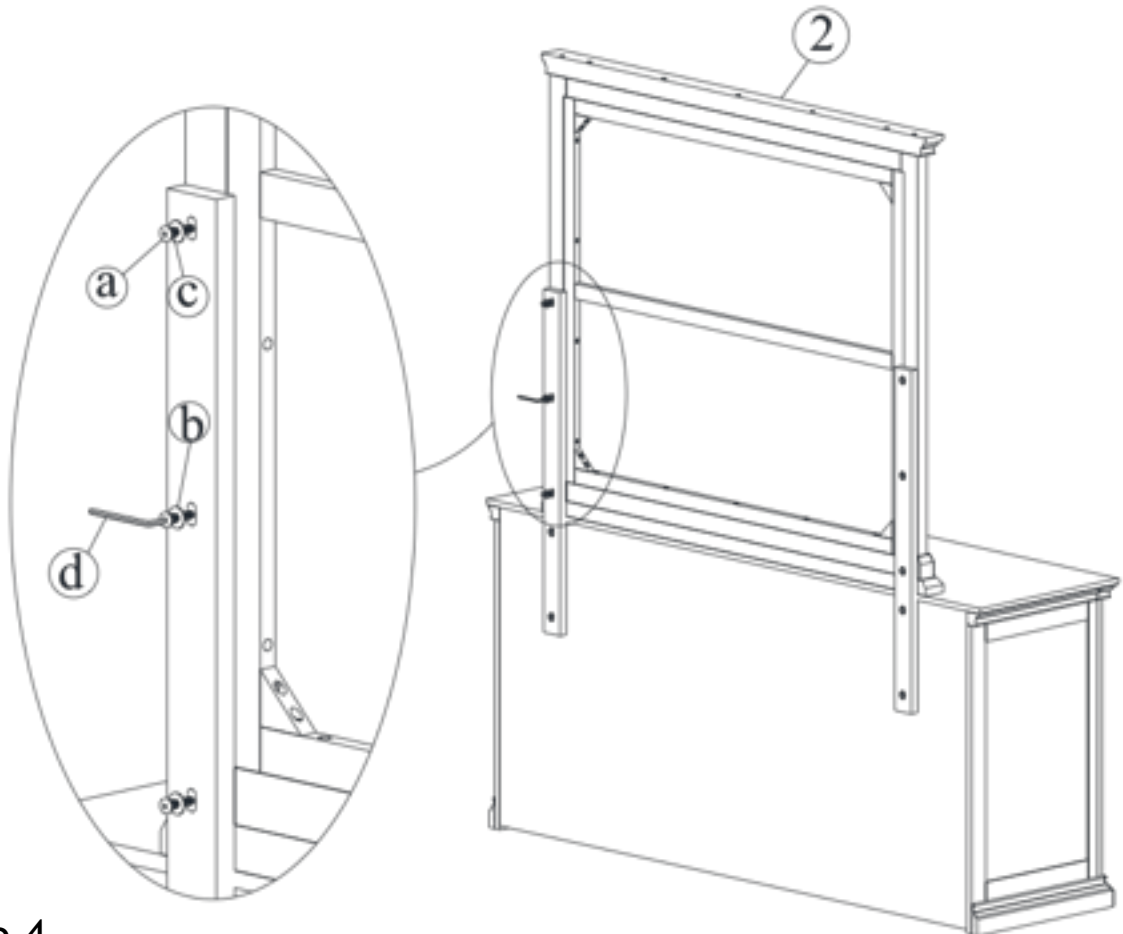

Step 4

With one person holding the mirror in place, fasten the 6 bolt sets from step 4, onto the mirror support bar as shown.

Removing the handles

Handles are installed on the inside for their own protection during transport. You will need to unscrew them and reattach them before use.

Step 1

Start by opening drawer with the string attached. Take a Phillips head screw driver and turn the screws counter clockwise. Take and store the screw safely once it is loose. As per the diagram on the left

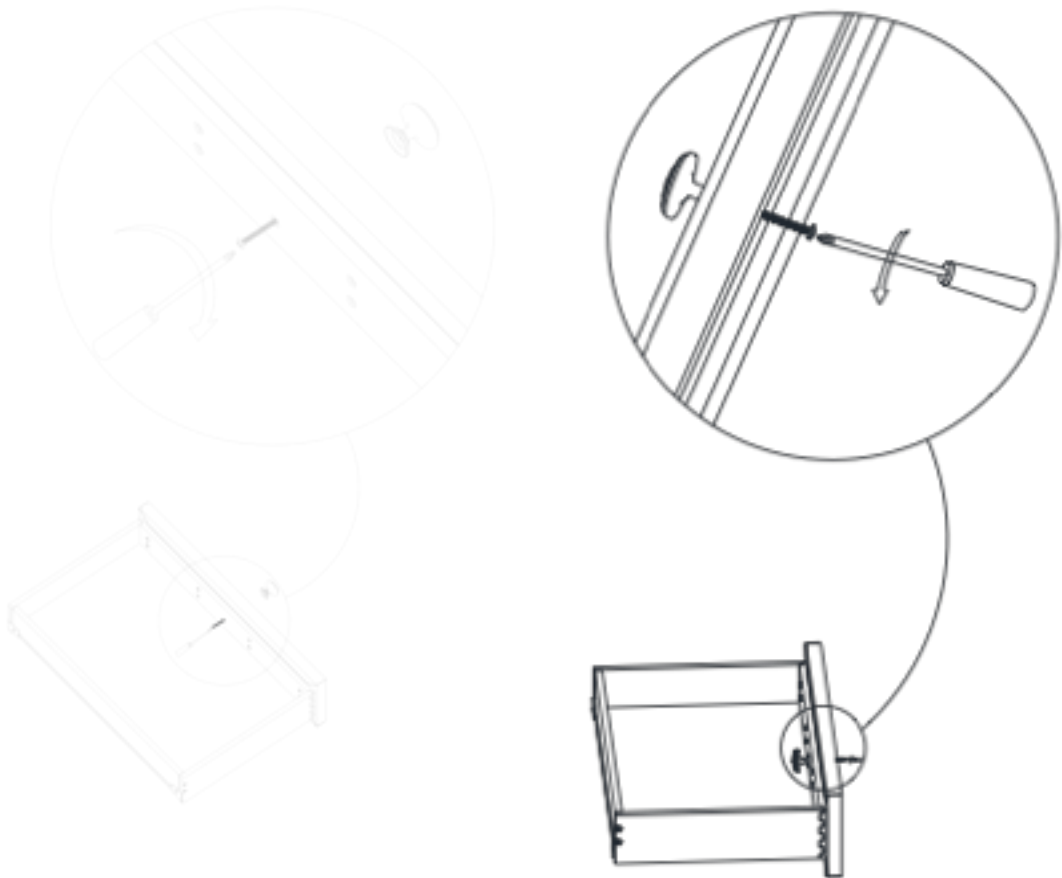

Step 2

Re-insert the screw from the inside. Hand turn the handle on the screw until it is secure, then tighten with a Phillips head screw driver until firmly fixed, as per the diagram on the right.

Attaching the anti-tipping kit.

As wall types vary, we do not supply the screws that you will need, to fasten onto your wall. Please seek advice from you trusted local specialist.

Step 1

Attach one of the anchors to the back of the dresser.

Step 2

Mark the spot on the wall that will best line up with the anchors already fixed on the unit. For best results we recommend placing the wall anchor to one side and not directly inline with the unit anchor.

Step 3

After sourcing the correct screw system for your wall type, fasten the wall side of the anchor.

Step 4

Move the unit into position and lock the uni anchor to the wall anchor together with the cable tie supplied. Do for each anchor point on the unit.

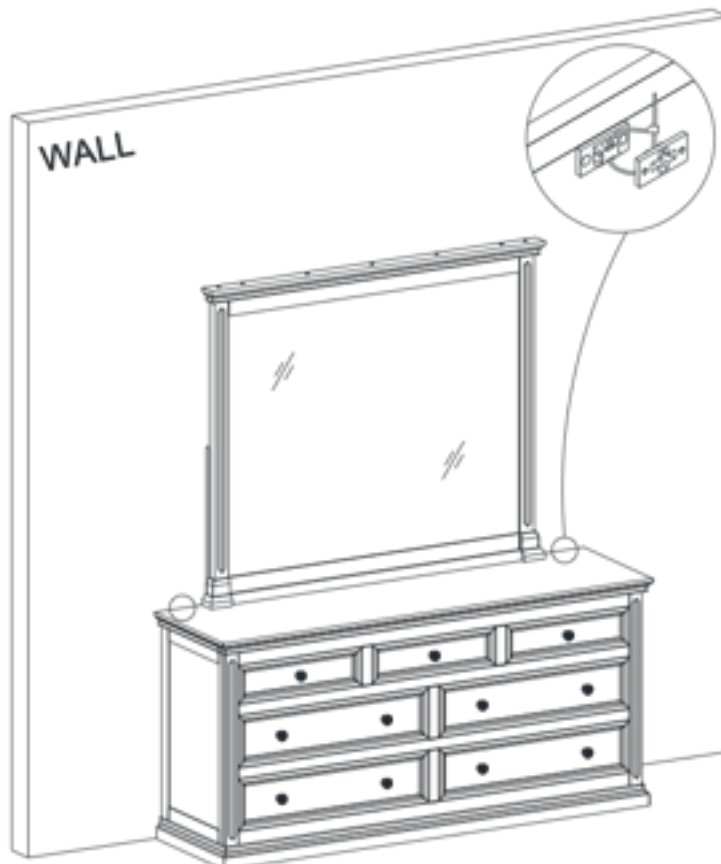

Assembly is complete

